



**TELESCOPE ASSEMBLY ALIGNMENT SIMULATOR
(TAAS) / SCIENCE INSTRUMENT (SI) INTERFACE CONTROL
DOCUMENT (ICD)
SSMO_SI_02**

SCI-AR-ICD-SE03-2020

Date: June 7, 2010

Revision: -



DFRC
Dryden Flight Research Center
Edwards, CA 93523

ARC
Ames Research Center
Moffett Field, CA 94035



German Space Agency, DLR
Deutsches Zentrum für Luft
und Raumfahrt

VERIFY THAT THIS IS THE CORRECT VERSION BEFORE USE

TELESCOPE ASSEMBLY ALIGNMENT SIMULATOR (TAAS)/SCIENCE INSTRUMENT (SI) INTERFACE CONTROL DOCUMENT

AUTHOR:



Robert Phillips / Lockheed Martin / Systems Engineer

6/14/10

Date

CONCURRENCE:

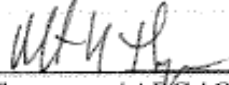

Robert R. Thompson / ARC / Orbital Sciences Corporation,
SOFIA Telescope Scientist and TAAS Work Product Lead

07 June 2010

Date

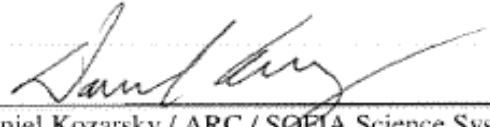

NASA / Daniel Kozarsky / ARC / SOFIA Science Systems
Engineering and Integration Lead

6/17/10

Date

APPROVALS:

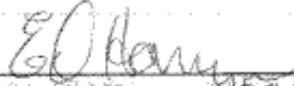

NASA / Ed Harmon / ARC / SOFIA Science Mission
Operations Manager

6/15/2010

Date



NASA / Scott Horner / ARC / SOFIA Science Instruments
Lead

16 June 2010

Date



NASA / Gelsomina Cappuccio / ARC / SOFIA Science Project
Manager

6/16/10

Date

VERIFY THAT THIS IS THE CORRECT VERSION BEFORE USE

TELESCOPE ASSEMBLY ALIGNMENT SIMULATOR (TAAS) / SCIENCE INSTRUMENT (SI) INTERFACE CONTROL DOCUMENT

Table of Contents

1.	INTRODUCTION.....	1
1.1.	PURPOSE.....	1
1.2.	SCOPE.....	1
1.3.	APPLICABLE DOCUMENTS	1
1.4.	SYSTEM DESCRIPTION	1
2.	INTERFACE REQUIREMENTS	3
2.1.	MECHANICAL INTERFACE REQUIREMENTS.....	3
2.2.	ELECTRICAL INTERFACE REQUIREMENTS.....	3
2.3.	SOFTWARE INTERFACE REQUIREMENTS	4
3.	VERIFICATION.....	5
3.1.	METHODS OF VERIFICATION	5
3.2.	TAAS VERIFICATION MATRIX	6
3.3.	SI VERIFICATION MATRIX	6
APPENDIX A.	ACRONYMS	7

Table of Figures

Figure 1	View of the TAAS, showing major structural components and TAAS coordinate system.	2
Figure 2	TAAS Host Computer and SCHP Client Computer connections.	3

VERIFY THAT THIS IS THE CORRECT VERSION BEFORE USE

TELESCOPE ASSEMBLY ALIGNMENT SIMULATOR (TAAS) / SCIENCE INSTRUMENT (SI) INTERFACE CONTROL DOCUMENT

1. INTRODUCTION

1.1. Purpose

This document defines the interface requirements between the Telescope Assembly Alignment Simulator (TAAS) and a SOFIA Science Instrument (SI).

1.2. Scope

The requirements in this document cover the mechanical, electrical, and software interfaces necessary to successfully install and operate a SI on the TAAS.

1.3. Applicable Documents

SCI-AR-SPE-SE01-040	Item Development Telescope Assembly Alignment Simulator (TAAS) Specification
SCI-AR-SPE-SW01-2010	TAAS Software Requirements Document
SE03-037 (SOF-ICD-KT-001)	TA_SI_02, Telescope Assembly / Science Instrument Mounting Interface
SE03-038 (SOF-ICD-MG-063)	TA_SI_04, TA Chopper Processor / Principal Investigator Computer Direct Analog Interface
TBD	User's Manual for the Light Sources and the Chopper Driver Control Units of the TAAS

1.4. System Description

The Telescope Assembly Alignment Simulator (TAAS) consists of the following major components and associated software:

- 1) Telescope Assembly Alignment Unit (TAAU)
- 2) Large Chopped Hot Plate (LCHP)
- 3) Small Chopped Hot Plate (SCHP)
- 4) Focused Chopped Light Source (FCLS)
- 5) Alignment Camera (AC)

VERIFY THAT THIS IS THE CORRECT VERSION BEFORE USE

The TAAS is used to perform fit checks of SOFIA Science Instruments with a duplicate of the Telescope Assembly (TA) Flange Assembly and permits adjustments, checkout, test, and characterization of Science Instruments (SIs) prior to installation and use aboard the Observatory. The TAAU is the main physical structure of the TAAS (see Figure 1). The TAAU consists of the INF vessel (shown in red in Figure 1), the Nasmyth tube (shown in yellow), and the Adjustable Source Mounting Flange (ASMF) (shown in black). A SI is attached to the Instrument Flange (INF) at one end of the TAAU and one of the three TAAS infrared sources is attached to the ASMF at the other end. The scale of the TAAU is designed so that the optical path length is 43% of the SOFIA Telescope Assembly's (TA) optical path length from the nominal focus to the TA secondary mirror.

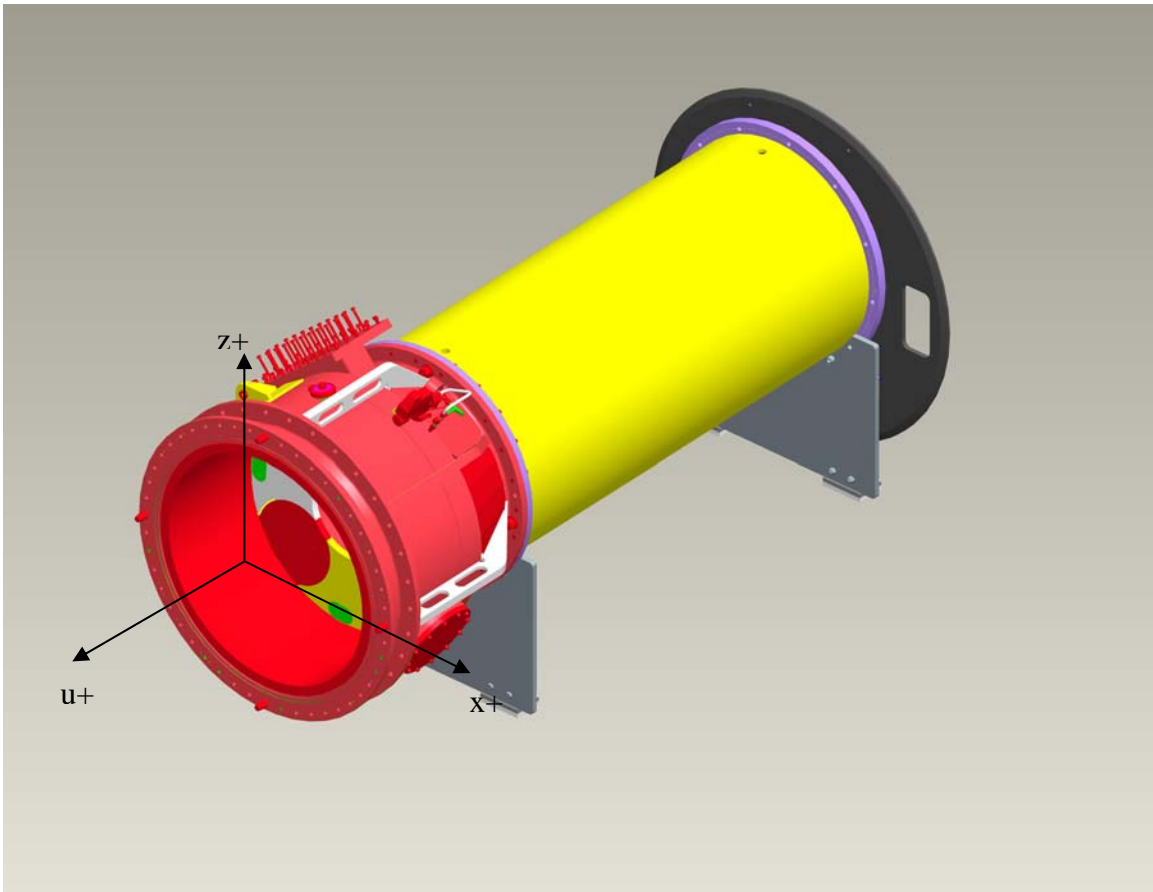

Figure 1 View of the TAAS, showing major structural components and TAAS coordinate system.

The TAAS will have three different infrared sources: the LCHP to simulate a “hot” secondary mirror for pupil imagers, a SCHP used mainly to map a SIs beam profile, and a FCLS which acts as a “point-like” source for focusing and alignment to the SI chip. The FCLS will include actuators for control of focus position, aperture position, and X-Z translation. The SCHP will include actuators for control of X-Z translation.

VERIFY THAT THIS IS THE CORRECT VERSION BEFORE USE

The TAAS will also include an Alignment Camera (AC) for maintaining the actual TA boresight transfer to the TAAS. In order to accomplish the initial boresight transfer, a SI (to be selected) will be installed on the SOFIA Telescope Assembly (TA) and aligned to the actual SOFIA TA boresight. The SI will then be removed from the TA and installed onto the TAAS. The FCLS will then be aligned to the SI-registered boresight pixel location. Herein, the TA boresight is transferred to the TAAS. The AC is then installed and pixel registration of the FCLS beam on the AC is noted. In the event that the FCLS loses the boresight, the AC is reinstalled and the FCLS position is aligned to the AC boresight pixel registration.

The Alignment Camera will not be used during normal operation of the TAAS, and is only used to re-align the FCLS to the boresight.

The TAAS will include a host computer responsible for multiple tasks including control of actuator positions, and transmission of SCHP data to an SCHP client computer. If a Science Instrument team plans to use the SCHP, they will need to provide a SCHP client computer. This computer will connect to the TAAS host computer via Ethernet and will access the TAAS computer using any common web browser.

TAAS Host computer and SCHP client Computer Connections are shown in Figure 2.

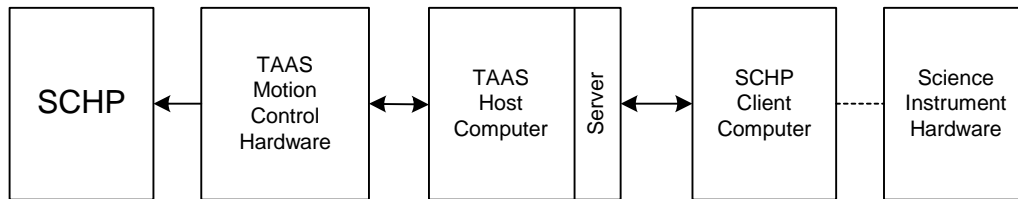

Figure 2 - TAAS Host Computer and SCHP Client Computer connections.

2. INTERFACE REQUIREMENTS

2.1. Mechanical Interface Requirements

The mechanical interface between the SI and the TAAS shall be identical to the SI to SOFIA Telescope Assembly interface, as defined in the ICD, Telescope Assembly / Science Instrument Mounting Interface, SE03-037, TA_SI_02_FL.

(Note: Bolts supplied by TAAS.)

2.2. Electrical Interface Requirements

2.2.1. Chopper Drive Control Unit(CDCU)/SI Connections

The following CDCU/SI connections shall be available:

- (1) CDCU Nod command
- (2) CDCU Nod status
- (3) CDCU Phase Command (frequency)

VERIFY THAT THIS IS THE CORRECT VERSION BEFORE USE

(4) CDCU Phase Status

2.2.2. CDCU / SI Cabling

Each connection between the CDCU and the SI shall be via a BNC-terminated, coaxial cable.

(Note: CDCU/SI cables supplied by TAAS)

2.2.3. Allowable Frequency Range

The TAAS shall accept an allowable frequency range for driving all three infrared sources of 1-20 Hz in continuous (chop) mode and 0 to 1 Hz in discrete stepping (nod) mode.

2.2.4. Chopper Drive Signal

The TAAS shall accept a SI generated chopper drive signal that is an optically isolated, TTL signal functionally equivalent to that required for driving the secondary mirror of the TA in accordance with SE03-038 (TA_SI_04).

2.2.5. Client to Host Connection

The SCHP Client Computer shall be connected to the TAAS Host Computer via Ethernet.
(Note: Ethernet cable supplied by TAAS)

2.3. Software Interface Requirements

2.3.1. SI Requirements

2.3.1.1. If using the SCHP, a Science Instrument Team shall provide a SCHP Client Computer with an Ethernet connection and common web browser for coordination with SCHP operations.

2.3.2. TAAS Requirements

2.3.2.1. The TAAS Server shall issue the SCHP Client Computer a dynamic IP address upon connection via Ethernet.

2.3.2.2. The TAAS Server shall command all actual SCHP motion.

2.3.2.3. The TAAS Server shall provide the capability for the Science Instrument Team to indicate their readiness to initiate a SCHP scan pattern.

2.3.2.4. The TAAS Server shall inform the Science Instrument Team when SCHP incremental moves are complete.

2.3.2.5. The TAAS Server shall provide the Science Instrument Team with the SCHP coordinates in a format that can be read and text-copied/pasted when incremental moves are complete.

2.3.2.6. The TAAS Server shall provide the capability for the Science Instrument Team to indicate their readiness for the SCHP to move to its next scanning position.

2.3.2.7. The TAAS Server shall inform the Science Instrument Team when a SCHP scan pattern is complete.

VERIFY THAT THIS IS THE CORRECT VERSION BEFORE USE

2.3.2.8. The TAAS Server shall provide the capability for the Science Instrument Team to download a list of SCHP scan point coordinates with time-stamps when a SCHP scan pattern is complete. The list shall be in a delimited text format.

3. VERIFICATION

3.1. Methods of Verification

Analysis: An element of verification that utilizes established technical or mathematical models or simulations, algorithms, charts, graphs, circuit diagrams, or other scientific principles and procedures to provide evidence that stated requirements were met.

Demonstration: An element of verification which generally denotes the actual operation, adjustment, or re-configuration of items to provide evidence that the designed functions were accomplished under specific scenarios. The items may be instrumented and quantitative limits of performance monitored.

Inspection: An element of verification consisting of investigation, without the use of special laboratory appliances or procedures, of items to determine conformance to those specified requirements, which can be determined, by such investigations. Examination is generally non-destructive and typically includes the use of sight, hearing, smell, touch, and taste; simple physical manipulation; mechanical and electrical gauging and measurement; and other forms of investigation.

Test: An element of verification, which generally denotes the determination, by technical means, of the properties or elements of items, including functional operation, and involves the application of established scientific principles and procedures.

NOTE: NVR = No Verification Required.

VERIFY THAT THIS IS THE CORRECT VERSION BEFORE USE

3.2. TAAS Verification Matrix

Paragraph ID	Title	Verification
2.1	Identical mechanical interfaces between SI/TAAS and SI/SOFIA TA	Inspection
2.2	Electrical Interface Requirements	N/A
2.2.1	Available CDCU/SI Connections	Inspection (Completed)
2.2.2	CDCU/SI cable type	Inspection (Completed)
2.2.3	Allowable frequency range for driving infrared sources	Test (Completed)
2.2.4	Optically isolated, TTL drive signal for the chopper drive signal	Analysis (Completed)
2.2.5	Client to host computer Ethernet connection and limited access	Demonstration
2.3	Software Interface Requirements	N/A
2.3.1	SI Requirements	N/A
2.3.1.1	SCHP Client Computer	N/A
2.3.2	TAAS Requirements	N/A
2.3.2.1	Dynamic IP address	Demonstration
2.3.2.2	TAAS server command of actual SCHP motion	Demonstration
2.3.2.3	Readiness to initiate SCHP scan pattern	Demonstration
2.3.2.4	Completion of SCHP incremental moves	Demonstration
2.3.2.5	Reading, text-copying and pasting SCHP coordinates	Demonstration
2.3.2.6	Readiness for the SCHP to move to its next scanning position	Demonstration
2.3.2.7	Completion of SCHP scan pattern	Demonstration
2.3.2.8	Download of SCHP scan point coordinates with time stamps	Demonstration

3.3. SI Verification Matrix

Paragraph ID	Title	Verification
2.3	Software Interface Requirements	N/A
2.3.1	SI Requirements	N/A
2.3.1.1	SCHP Client Computer	Demonstration

VERIFY THAT THIS IS THE CORRECT VERSION BEFORE USE

APPENDIX A. ACRONYMS

AC	Alignment Camera
ASMF	Adjustable Source Mounting flange
ARC	Ames Research Center
BNC	Bayonet Neill-Concelman
CDCU	Chopper Drive Control Unit
COTS	Commercial off the shelf
DFRC	Dryden Flight Research Center
FCLS	Focused Chopped Light Source
INF	Instrument Flange
LCHP	Large Chopped Hot Plate
NASA	National Aeronautics and Space Administration
SCHP	Small Chopped Hot Plate
SI	Science Instrument
TA	Telescope Assembly
TAAS	Telescope Assembly Alignment Simulator
TAAU	Telescope Assembly Alignment Unit

VERIFY THAT THIS IS THE CORRECT VERSION BEFORE USE